

# Self-Compacting Concrete Using GGBS with Addition of Steel Fibers on M30 Grade of Concrete

E. Mani<sup>1</sup>, K. Showri Bhargav<sup>2</sup>, Y. Nagaraju<sup>3</sup>, V. Sailaja<sup>5</sup>, and P. Rudhra Venu<sup>6</sup>

<sup>1,2</sup>Assistant Professor, Department of Civil Engineering, PACE Institute of Technology & Sciences, Ongole, Andhra Pradesh, India

<sup>3,4,5,6</sup>B. Tech Scholar, Department of Civil Engineering, PACE Institute of Technology & Sciences, Ongole, Andhra Pradesh, India

Copyright © 2023 Made E. Mani et al. This is an open access article distributed under the Creative Commons Attribution License, which permits unrestricted use, distribution, and reproduction in any medium, provided the original work is properly cited

**ABSTRACT-** Self-compacting concrete has emerged as a creative invention that is capable of solving the problem and making a remarkable advancement in the field of substantial innovation, which has led to the prior practise of substantial design free from vibration. Self-compacting concrete use today is focused on higher performance, better and more solid quality, and uniformity. Self-compacting concrete (SCC) with GGBS and blended steel strands is being created in this research. The goal of this work is to create M30 SCC with GGBS cream steel fibers and compare its strength to normal concrete. The IS 10262 2009 standard is used to produce regular cement, whereas the alter Nan Su approach is used to produce SCC. In order to increase the volume of cement, the significant is replaced by 0, 10, 20, 30, and 40% of GGBS with the addition of stable steel strands at a 0.5% expansion. The compressive strength of SCC is determined using 3D squares of size 150x150x150mm, while the split tensile strength is determined using cylinder-shaped examples of size 150x300mm, and the flexural strength of SCC is determined using crystals of size 100x100x500mm.

**KEYWORDS-** Ground granulated blast boiler slag, self-compacting concrete (SCC), FA (fine aggregate), CA (coarse aggregate), and OPC (ordinary portland cement)

## I. INTRODUCTION

Due to the rebar's packed structure in reinforced concrete (RC) parts like columns and beams, it is difficult to properly compact concrete when using a mechanical vibrator. Unfilled voids and macro-pores that develop in the concrete as a result of incorrect vibration and compaction are one of the potential reasons of concrete deterioration. Self-compacting concrete (SCC), also known as self-consolidating concrete or hemodynamic concrete, does not require vibration for placement and compaction. Even in the midst of crowded reinforcement, it can flow under its own weight, completely filling forms and attaining full compaction.

The main objective of this research aims to increase the concrete strength and durability.

Super plasticizer used to increase the strength and workability of the concrete, super plasticizers are Fly Ash and GGBS (ground granulated blast furnace slag), During

concrete casting, the need for vibration is minimal and thus labor and time are saved. Creating a smooth concrete surface facilitates the gauging process. It increases the durability by creating a space-free structure between concrete and iron reinforcement, by preventing segregation, it provides a homogeneous concrete without air bubbles. The permeability of self-compacting concrete is lower than normal concrete, its insulation values are higher.

## II. LITERATURE REVIEW

Sonebi et al. (2003) [1] demonstrated that the load deflection response and mechanism of failure of the beams cast with SCC and regular concrete were comparable. It was found that, for concrete with a compressive strength of 60 MPa, the ultimate moment capacity of the SCC beam was similar to that of the NC beam and that its maximum deflection was marginally greater than that of the reference beam. The shear strength of the interface between pre fractured surfaces under various levels of normal stress was taken into consideration in

Chisels. Zilch's studies from 2001[2] on the contribution of aggregate interlock to the shear strength of cracked sections. It was discovered that due to smoother crack surfaces, SCC had a shear strength for any given normal stress that was about 10% lower for comparable concrete strength.

Hassan (2012) [3] studied the effect of shear span to effective depth ratio, amount and arrangements of web reinforcement on the shear strength of SCC deep beams. It was found that, as the shear span to effective depth ratio decreased from 1.2 to 0.8, the percentage of increase in the failure load was about 32.5 %. The percentage of increase in the failure load were 42.6%,27.7%,19.1%, as both horizontal and vertical,

horizontal only and vertical only web reinforcement ratios increased from 0% to 0.168%. Up to date, a number of researches on structural behaviour and performance of RC structures made with SCC was carried out. However, there is limited number of experimental and theoretical studies on the structural behaviour reinforced beams and slabs made with SCC.

### III. METHODOLOGY

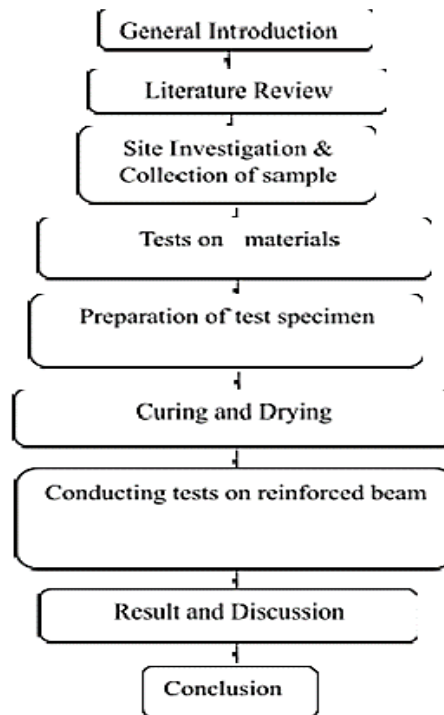

Figure 1: Mix proportion of SCC and NC

Table 1: Properties of fresh SCC and NC

CONCRETE TYPE	MIX SYMBOL	Cement (kg/m <sup>3</sup> )	LSP (kg/m <sup>3</sup> )	Water (kg/m <sup>3</sup> )	Sand (kg/m <sup>3</sup> )	Gravel (kg/m <sup>3</sup> )	SP/C %by wt.
SCC	SCC40	385	150	181	765	955	0.79
	SCC50	450	174	174	774	893	0.88
NC	NC40	384	182	180	726	1156	0
	NC50	551	174	176	676	1116	0.25

#### Preparation of Specimen

The Engineering College's Building Materials Lab at Basrah University was where the six concrete mixtures for this investigation were cast. The qualities of the freshly mixed concrete were tested, and beams and slabs

were immediately cast into pre-made wooden shapes. SCC beams were built by pouring concrete into the formwork from one side and letting it flow to the other without needing any consolidation.

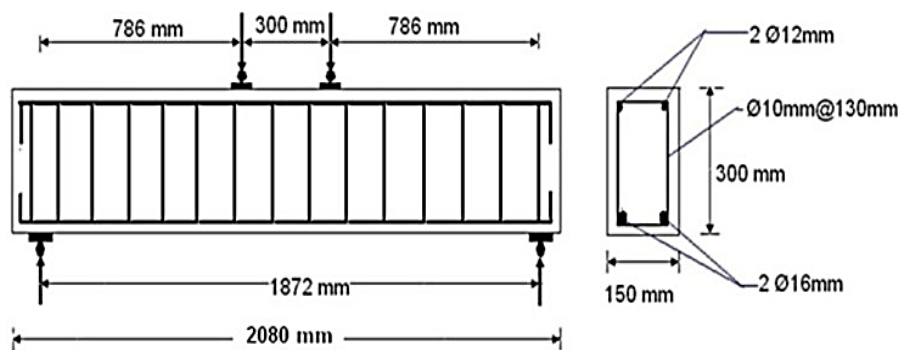

Figure 2: Preparation of specimen

**IV. RESULTS AND DISCUSSION**

The outcomes of the experiments done on the First cracking load, ultimate load, measured moment at ultimate load, and deflection at service load for beams intended to fail in flexure were among the test observations. Examples of deflection, crack width, and crack pattern for certain specimens are shown in Figures (6) to (14). California Bearing Ratio



Figure 3: Test setup of tested specimen's beams

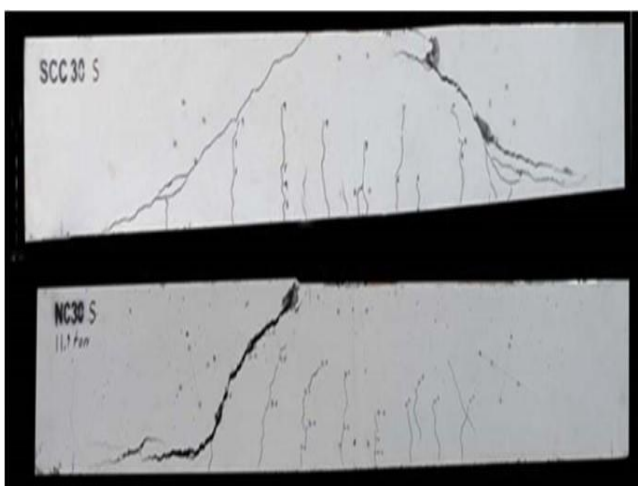

Figure 4: Crack pattern of SCC and NC slender beams failed in shear

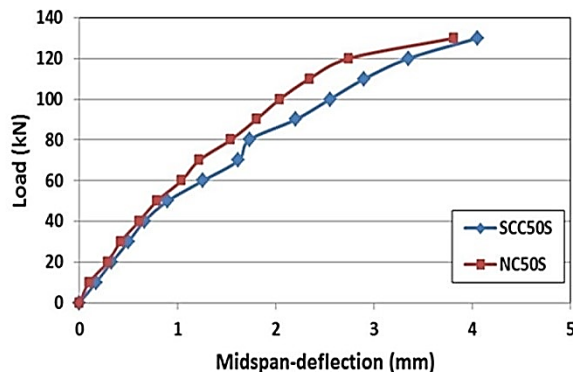

Figure 5: Load midspan deflections curve for SCC and NC slender beams failed in shear.

Test results of beams designed to fail in flexure However, Table (5) shows that the ultimate load rises with an increase in  $f_c'$  for both types of concrete, with beam (SCC50S) displaying a higher ultimate load than beam (SCC30S) of 18.2% and beam (SCC62S) displaying a higher ultimate load than beam (SCC50S) of 37.3%. While the ultimate loads of beams (NC50S) and (NC62S) are, respectively, 15.1% and 26% greater than beam (NC30S). This is attributed to that, after an angled fracture appeared, the dowel force in the longitudinal reinforcement began resisting shearing displacement at the crack, and that resistance tended to generate tensile stresses in the tension steel surrounding concrete. Splitting cracking along the reinforcing and a failure in the tension zone occurred when forces surpassed the concrete's tensile strength. As a result, the dowel force increases as  $f_c'$  grows because  $f_c'$  It is clear that the effect of concrete compressive strength is more obvious for beams failed in shear than for those failed in flexure (SCC), which display somewhat higher midspan deflection than equivalent beams of group (NC) at all loading stages. The lower elastic modulus of the self-compacting concrete utilised to make these beams is what is responsible for the rise in deflection for beams (SCC). When concrete's compressive strength is increased, both SCC and NC beams' deflections are reduced.

Table 3: Test results of beams designed to fail in flexure

Beam	Cracking load (kN) (1)	Ultimate load (kN) (2)	Ratio (1)/(2) %	Ultimate moment KN.m (3)	Calculated moment KN.m (4)	Ratio (3)/(4)	Service Load (KN)	Measured Deflection at service load(mm) (5)	Calculated Deflection at service load(mm) (6)	Ratio (5)/(6)
SCC40F	42	165	25.4	6502	48.26	1.286	102.57	3.58	3.35	0.95
SCC50F	43	170	24.8	66.5	50.52	1.236	105.02	3.49	3.55	0.96
NC40F	36	163	21.0	62.1	48.26	1.922	102.45	3.25	3.28	0.99
NC50F	38.5	175	22.3	65.8	52.30	1.096	105.28	3.15	3.35	0.97

Test results of beams designed to fail in shear with  $a/d=3$  (Slender Beams)

Table 4: Test results of beams designed to fail in shear with a/d=3 (Slender Beams)

Beam	Flexural cracking load (kN) (1)	Ultimate load(kN) (2)	Ratio (1)/(2) %	Predicted ultimate load (kN)			Ratio (2)/(3)	Ratio (2)/(4)	Ratio (2)/(5)
				ACI (3)	EC-2 (4)	BS8110 (5)			
SCC30S	42	112	35.37	75.2	97.5	93.7	1.32	1.15	1.19
SCC50S	43	135	33.20	91.6	109.4	102.0	1.45	1.19	1.22
NC30S	35	115	30.35	74.8	96.3	94.1	1.59	1.25	1.26
NC50S	37	139	26020	92.1	110.5	105.2	1.49	1.28	1.35

From the test results obtained in this study the following conclusions can be drawn:

For beams designed to fail in flexure, beams made with SCC showed 11.6% higher cracking load than similar beams made with NC. For the ultimate load, no considerable difference between NC and SCC beams was observed. NC. For the ultimate load and for beams with  $f_c'$  of about 32 and

48 MPa, NC beam showed 6.75 % higher ultimate load compared with SCC beams. For the ultimate load of SCC and NC beams with  $f_c'$  of about 62 MPa, SCC beam gave almost the same ultimate load value. SCC beams showed an inclined cracking load that was 7.3% higher than that of comparable NC beams for deep beams (a/d=1) that collapsed in shear. There was no discernible difference between NC and SCC beams for the final load. By lowering the a/d ratio, the ultimate shear force was significantly increased. Reducing the a/d ratio from 3 to 1 resulted in a rise of (433%) for SCC beams without web reinforcement.

SCC slabs showed a 16.6% greater flexural cracking load than comparable NC slabs for slabs that failed in punching shear. SCC slabs showed a 17.25% greater ultimate load than comparable NC slabs for the ultimate load.

All NC beams had fewer flexural fractures than comparable SCC beams, but the SCC beams' flexural cracks were narrower. The deflection of SCC beams for the same loading amount was marginally greater than for comparable NC.

## CONFLICTS OF INTEREST

The authors declare that they have no conflicts of interest.

## REFERENCES

- [1] Broomfield, J. 2003., "The identification and assessment of defects damage and decay". In S. MacDonald (Ed.), Concrete: Building pathology. Oxon: Blackwell,
- [2] Sonebi, M., Tamimi, A. K. and Bartos, P. J. M., 2003, "Performance and Cracking Behavior of Reinforced Beams Cast with Self-Consolidating Concrete", ACI Material Journal, Vol. 100, No.57, May-June, pp. 492-500.
- [3] Schiessl, A. and Zilch, K., 2001, "The Effects of the Modified Composition of SCC on Shear and bond Behavior", Proceedings of the second RILEM international symposium on self-compacting concrete, Ozawa, K. and Ouchy M. Editors, Kochi University of Technology, Japan: COMS Engineering Corporation, pp. 501-506
- [4] Hassan, S.A., 2012, "Behavior of Reinforced Concrete Deep Beams using Self Compacting Concrete" Ph.D. Thesis, College of Engineering, Baghdad University March 156 pp.
- [5] Iraqi Standards No.45/1984, "Aggregate from Natural Sources for Concrete and Construction", Ministry of Housing and Construction, Baghdad.
- [6] ASTM C494-04, 2004 "Standard Specification for Chemical Admixtures for Concrete", Vol. 4.2, pp. 1-9.
- [7] ASTM C143 M-03, "Standard test method for slump of hydraulic cement concrete", Vol. 4.2, 2003, pp. 1-5.
- [9] EFNARC, 2005 "The European Guidelines for Self Compacting Concrete Specification, Production and Use", European Federation of Producers and Applicators of Specialist Products for Structures, May.